

Water pump 3" with pulley SU-80

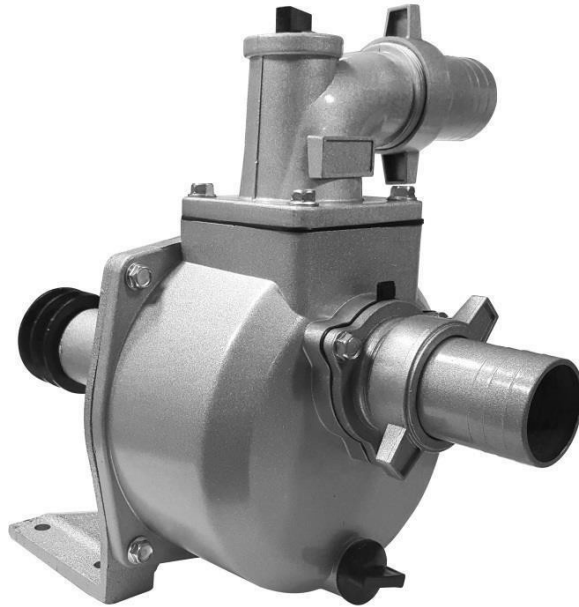

Instructions for use

Translation of the original instructions

GENERAL SAFETY RULES

Attention:

Please read the following operating instructions carefully with understanding all rules for safe use. Failure to do so may result in damage to the equipment or personal injury.

Once you have read it, keep the manual in an easily accessible place so that you can consult it at any time while working with the device.

THE MEANING OF SYMBOLS



Read the operating instructions with understanding

The user is obliged to observe the operating instructions and instruct all users of the tool in its use.



Wear eye protection. (Goggles, safety glasses, masks).



Wear work gloves

SAFE USE

1. Keep the work area tidy. A messy workplace can cause accidents.
2. Do not use the tool in the presence of children and do not allow children access to the tool facility.
3. Exercise maximum caution and full concentration during use. Do not work under the influence of alcohol, drugs or other substances that impair concentration.
4. Avoid loose clothing, ties, jewelry, long hair. They can be pulled in by moving parts of the machine.
5. Wear protective equipment such as goggles, safety gloves.
6. Keep your balance when working. Wear non-slip footwear.
7. The pump is designed for pumping clean water only. Do not pump other liquids, especially particularly flammable liquids.
8. Do not leave the machine unattended in operation.
9. Always use a belt and pulley guard. Do not unscrew the covers while the pump is running.
10. Do not use a pump on which damage has been detected. Working with a damaged pump is dangerous.
11. Do not interfere with the pump design.

PUMP INSTALLATION

1. Mount the pump on a stable surface and fix it with a suitable bracket.
2. Make sure that the motor that connects to the pump has sufficient power.
3. Select a drive belt with the correct width. Make sure it has always been tensioned correctly. The pulleys and belt should be covered.
4. The operating speed of the pump is 3600 rpm. Select the diameter of the pulleys to achieve the correct speed.

$n_{obr. pompy} = \frac{\varnothing \text{ engine wheel speed}}{\varnothing \text{ engine speed}}$

$\varnothing \text{ pump wheel}$

5. Observe the correct direction of rotation of the pump. It should be in line with arrows on the cover. Starting the pump in the wrong direction will lead to its Damage.
6. Maintain a minimum distance of 1 m between the drive shaft and the pump shaft.

WATER PUMPING

1. The pumped water must not be turbid, the temperature should be between 0 - 80C and the pH between 5 - 9.
2. The head with outlet can be mounted in four positions.
During installation, make sure that the gasket is properly fitted and undamaged.
3. All joints must be tight. Air ingress can cause pump failure. Check the connections for tightness before each use.
4. The suction hose should be reinforced and original. The length of the suction hose should not be longer than necessary, as the pump works most efficiently when it is at a low height above the water surface.

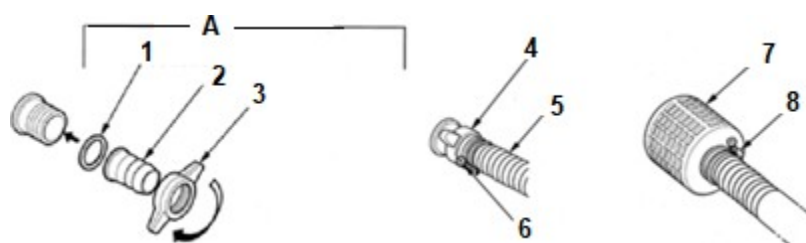

A) Hose connection

- | | | |
|-----------------|----------------|-------------------|
| 1. Seal | 4. Krydl's nut | 7. Suction basket |
| 2. Hose cap | 5. Hose | 8. Clamp |
| 3. Krrydl's nut | 6. Clamp | |

5. Always use a suction basket at the end of the suction hose. It catches solid dirt with an unacceptable diameter. Sucking in dirt can cause the pump to clog or damage components inside the cabinet. The suction basket should always be completely submerged in water.
6. Use generally available drain hoses to drain the water. Larger Efficiency is achieved by using short, large diameter hoses. With a long hose with a small diameter, the resistance to the movement of the pumped liquid increases, thus reducing the efficiency of the pump.
7. Fill the pump chamber before commissioning. Make sure the plugs are tightened securely. Never run the pump dry. Do not loosen the plugs while the pump is running.
8. When the work is finished, drain the water from the chamber by unscrewing the bottom plug.

SPECIFICATION

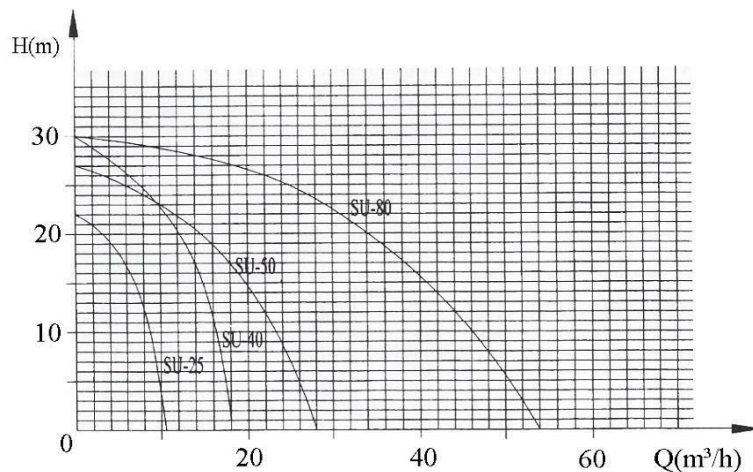
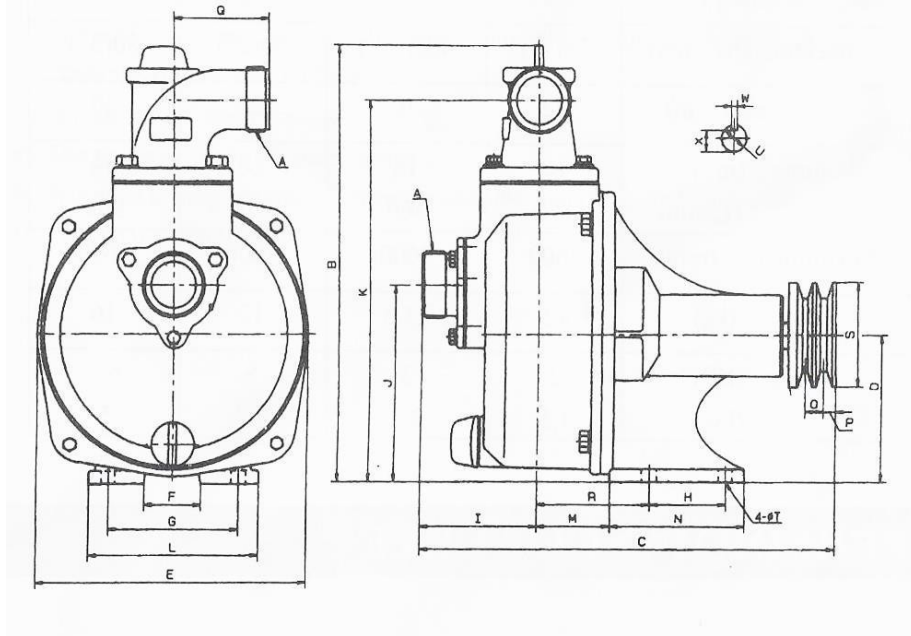

Fig.1 Schematic diagram of the relationship between flow rate (Q) and height (H).

Model	SU-25	SU-40	SU-50	SU-80
Outlet diameter	25 mm (1")	38 mm (1.5")	50 mm (2")	80 mm (3")
Maximum lifting height	21m	24m	35m	35m
Maximum capacity	15m ³ /h	20m ³ /h	25m ³ /h	35m ³ /h
Recommended engine power	2.0HP (1.5 kW)	3.0HP (2.2 kW)	5.0HP (3.7 kW)	6.5 HP (5.0 kW)
Turnover	3600 rpm	3600 rpm	3600 rpm	3600 rpm
Weight	8,5 kg	11,5 kg	12,0 kg	16,0 kg

Tab.1 Technical parameters.

DIMENSIONS



(mm)	A	B	C	D	E	F	G	H	I	J
SU-25	25	260	290	90	174	88	115	48	100	130
SU-40	38	310	340	110	210	104	160	60	100	130
SU-50	50	330	360	110	210	104	160	80	100	145
SU-80	80	390	390	120	238	130	170	80	120	160
	K	L	M	N	O	P	Q	R	S	T
SU-25	235	152	50	90	15	9	60	80	60	10,5
SU-40	235	192	50	90	15/19	9/12,5	90	80	80	10,5
SU-50	290	192	65	125	15/19	9/12,5	90	90	80	10,5
SU-80	345	205	80	125	15/19	9/12,5	100	100	80	10,5

DISTRIBUTED VIEW

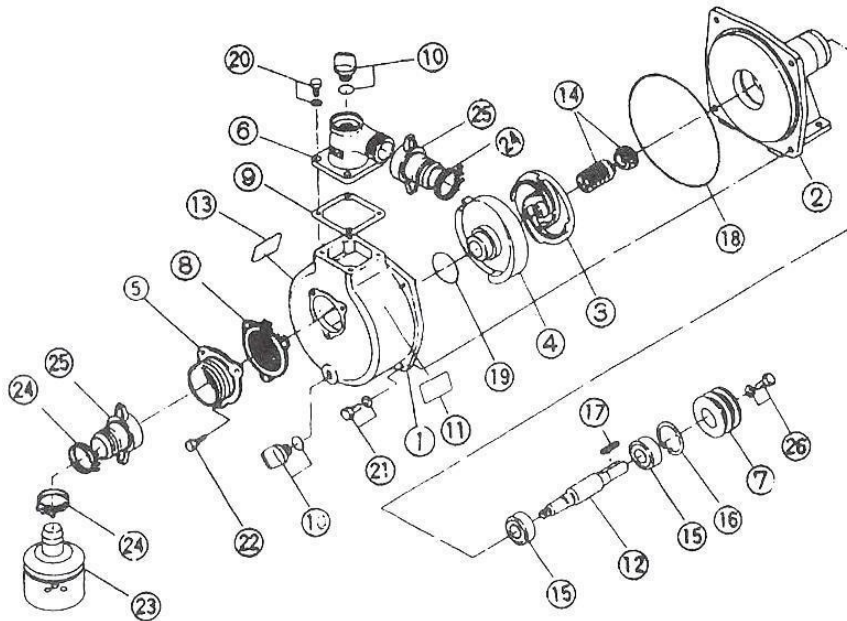

SU-25

No.	Description	Quantity	No.	Description	Quantity	Dimension
1	Front cover	1	14	Mechanical sealing	1	108-20
2	Back cover	1	15	Bearing	2	6204
3	Rotor	1	16	Pad	1	Ø47
4	Rotor cover	1	17	Key	1	6x25
5	Suction port	1	18	O-ring	1	Ø160x4
6	Spout nozzle	1	19	O-ring	1	Ø42x3,55
7	Hammer	1	20	Screw	4	M6x16
8	Check valve	1	21	Screw	4	M6x16
9	Seal	1	22	Screw	3	M6x16
10	Korok	2	23	Suction basket	1	
11	A label with the name	1	24	Clamp	3	Ø25 mm
12	Shaft	1	25	Hose connection	2	
13	Sticker	1	26	Screw	1	M6x14

SU-40

No.	Description	Quantity	No.	Description	Quantity	Dimension
1	Front cover	1	14	Mechanical sealing	1	108-20
2	Back cover	1	15	Bearing	2	6204
3	Rotor	1	16	Pad	1	Ø47
4	Rotor cover	1	17	Key	1	6x25
5	Suction port	1	18	O-ring	1	Ø196x4
6	Discharge nozzle	1	19	O-ring	1	Ø54x7
7	Hammer	1	20	Screw	4	M8x25
8	Check valve	1	21	Screw	4	M8x25
9	Seal	1	22	Screw	3	M8x20
10	Korok	1	23	Suction basket	1	
11	A label with the name	1	24	Clamp	3	Ø50 mm
12	Shaft	1	25	Hose connection	2	
13	Sticker	1	26	Screw	1	M6x14

SU-50

No.	Description	Quantity	No.	Description	Quantity	Dimension
1	Front cover	1	14	Mechanical sealing	1	108-20
2	Back cover	1	15	Bearing	2	6204
3	Rotor	1	16	Pad	1	Ø47
4	Rotor cover	1	17	Key	1	6x25
5	Suction port	1	18	O-ring	1	Ø1960x4
6	Discharge nozzle	1	19	O-ring	1	Ø54x7
7	Hammer	1	20	Screw	4	M8x25
8	Check valve	1	21	Screw	4	M8x25
9	Seal	1	22	Screw	3	M8x20
10	Korok	1	23	Suction basket	1	
11	A label with the name	1	24	Clamp	3	Ø50 mm
12	Shaft	1	25	Hose connection	2	

13	Sticker	1	26	Screw	1	M6x14
----	---------	---	----	-------	---	-------

SU-80

No.	Description	Quantity	No.	Description	Quantity	Dimension
1	Front cover	1	14	Mechanical sealing	1	108-20
2	Back cover	1	15	Bearing	2	6205
3	Rotor	1	16	Pad	1	Ø52
4	Rotor cover	1	17	Key	1	8x25
5	Suction port	1	18	O-ring	1	Ø220x4
6	Spout nozzle	1	19	O-ring	1	Ø74x7
7	Hammer	1	20	Screw	4	M10x25
8	Check valve	1	21	Screw	4	M10x25
9	Seal	1	22	Screw	3	M10x20
10	Flooding stopper	1	23	Suction basket	1	
11	A label with the name	1	24	Clamp	3	Ø80 mm
12	Shaft	1	25	Hose connection	2	
13	Sticker	1	26	Screw	1	M8x14

PROBLEM SOLVING

The problem	Cause	Solution
The pump does not rotate	<ol style="list-style-type: none"> 1. Defective bearing 2. Rotor dirty 	<ol style="list-style-type: none"> 1. Replace the bearing 2. Clean the rotor
Low water flow	<ol style="list-style-type: none"> 1. Leakage in the suction section 2. Damage to the seal mechanical seal 3. Suction height too high 4. Twisted or kinked hose 5. Insufficient hose section 	<ol style="list-style-type: none"> 1. Check connections and hoses 2. Replace mechanical seal 3. Reduce the suction height 4. Check the condition of the hose 5. Use a hose with the correct cross-section
The pump does not feed	<ol style="list-style-type: none"> 1. air supply 2. Insufficiently flooded chamber 3. Insufficiently tightened hoses 4. Faulty sealing mechanical seal 	<ol style="list-style-type: none"> 1. Check the tightness of the connections 2. Fill the chamber to the brim 3. Properly clamp the clamps correctly clamp the clamps 4. Replace mechanical seal

MAINTENANCE AND STORAGE

1. Do not leave the pump with the chamber flooded.
2. When not in use, store the pump in a dry place out of reach of children.
3. Keep the unit clean.

ENVIRONMENTAL PROTECTION



Do not dispose of the appliance with other municipal waste at the end of its useful life